

# Air Comm Systems, Inc.

## Single Audio Mixer Panel Installation and Operations Manual

ACS 775A-SL

Revision 1.0

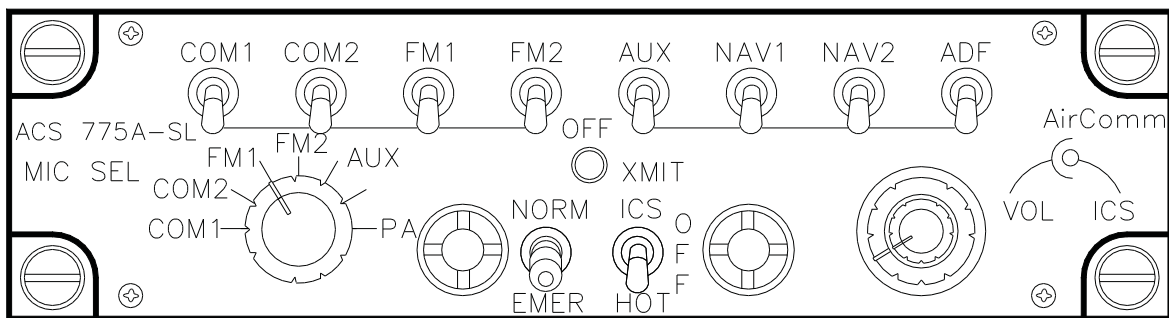

# AirComm

Airborne Audio Products

**Air Comm Systems Inc.**  
1640 W. Acoma Blvd., Suite A-118  
Lake Havasu City, AZ 86403  
Phone (928) 854-5402  
FAX (928) 854-8919  
E-Mail [aircomminc@aol.com](mailto:aircomminc@aol.com)

# ACS 775A-SL Installation and Operations Manual

## Table of Contents

### ■ Installation

Physical and Operating Specifications	Page 3
Physical Dimensions	Page 4
Interface Schematic	Page 5

### ■ Operation

Front Panel Controls	Page 6-7
Front and Rear Panel Controls Pictorial	Page 8

### ■ Instruction for Continued Airworthiness

Instruction for Continued Airworthiness	Page 9
---	--------

### ■ Warranty Information

Warranty Information	Page 10
----------------------	---------

### ■ Supplemental Information

Product Schematics	_____
--------------------	-------

# ACS 775A-SL Installation and Operations Manual

## Physical and Operating Specifications

### ■ Physical Specifications

*SIZE:* 5.75 in. (14.61cm) W  
1.50 in. (3.81 cm) H  
5.03 in. (12.77cm) D

*WEIGHT:* 1.25 lb. (.56kg)

*MOUNTING:* Dzus rail mount

*CONTROLS:* Panel mounted - transmit = rotary switch, audio inputs = toggle switch,  
volume control = dual potentiometer

*ILLUMINATION:* Edge lit front panel per MIL-P-7738E, type 3. Capable of connection to  
dimmer bus for adjustment. Amber transmit light indicates when unit is  
in transmit mode.

### ■ Operating Specifications

*INPUTS:* 8 selectable receive audio inputs and up to 7 transmit selections.

*DUTY CYCLE:* Continuous

*POWER REQUIREMENTS:* 28V DC +/- 10%

*MAXIMUM OPERATING ALTITUDE:* 16,500 ft.(5029 m)

*OPERATING TEMPERATURE RANGE:* -40 C to +85 C (operating)  
-65 C to +125 C (storage)

*CURRENT DRAIN:* 70 mA at 28V (standby) - 500mA at 28V (max. signal)

*AUDIO OUTPUT:* Minimum 250 mW into 600 ohms

*FREQUENCY RESPONSE:* Within 6 db - 300-3000Hz

*ICS INPUT IMPEDANCE:* 600 ohms

*RECEIVER INPUT IMPEDANCE:* 600 ohms - matched to receiver

*INPUT ISOLATION:* Not less than 50 db between inputs

*AUDIO MUTING:* Not less than 40 db during transmit/ICS (optional)

*MIKE SENSITIVITY:* 300 mV for rated output

*DISTORTION:* Less than 10% at 1000 Hz for maximum output

# ACS 775A-SL Installation and Operations Manual

## Physical Dimensions

### ■ Physical Dimension Outline for mounting

UNIT WIDTH BEHIND FACE PLATE

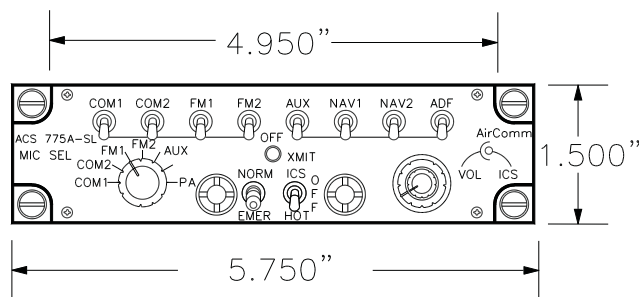

FRONT PANEL WIDTH – STANDARD DZUS MOUNT

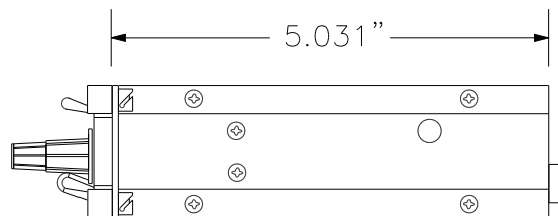

ALLOW UP TO 2.500" FOR REAR  
CONNECTOR AND CABLE CLEARANCE

### Physical Installation

The ACS 775A-SL is designed to be Dzus mounted and should be installed in the aircraft using the DC37SL-F Installation kit that is included. The above outline drawing of the unit with dimensions will facilitate the installation.

The connector pin configuration of the ACS 775A-SL rear connector and the recommended wire size for the aircraft cable harness is shown on the following page. Be sure that adequate clearance is allowed for the rear connector and cable harness.

# ACS 775A-SL Installation and Operations Manual

## Interface Schematic

### ■ Connector Pin-out

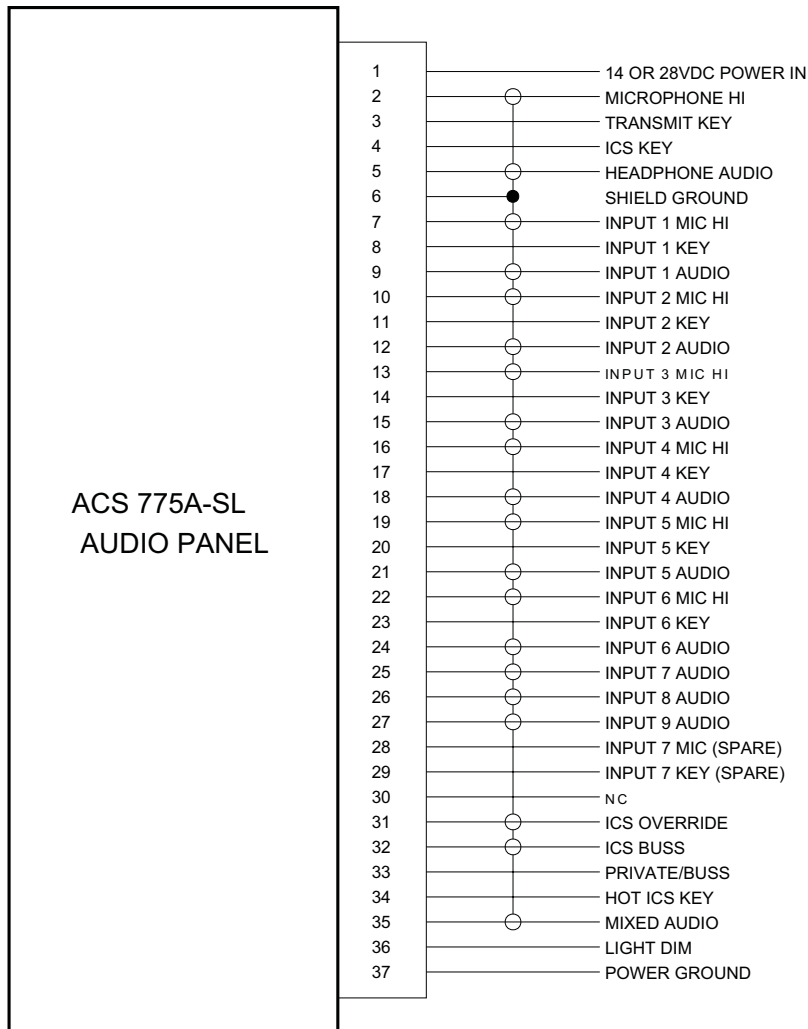

The ACS 775A-SL wiring harness should be constructed of Tefzel aircraft wire (M22759/16 grade). Power and ground wires should be 18 or 20 AWG, and all other wires may be 22 AWG. Shielded wires should be used where noted. Adequate protection against wear and chafing should be taken by using a braided cable sleeving or jacket. Before completing installation, verify that all cable connector pins are seated properly and that the connector is securely mounted to the unit mating connector. **Important — please note the power of the unit before installing; it will be either 14VDC or 28VDC and clearly marked as such on the unit's data tag.**

Pre-fabricated cable harnesses are available from Air Comm to expedite installation — consult our sales department for details.

# **ACS 775A-SL Installation and Operations Manual**

## **Front Panel Controls**

*(See Figure 1 - Page 8 for pictorial)*

### **1- NORM - EMER SWITCH**

This switch controls the operation of the audio panel in the event of an audio amplifier failure. In the "up" position (NORM) the audio panel is in normal operating mode. In the "down" position (EMER) all audios are summed and then fed directly to the headphones. This enables the use of the transmitters and other equipment during audio amplifier failure.

### **2 - RECEIVE AUDIO SELECT-MUTE SWITCHES**

Normal operation - In the "up" position the audio selected is channelled to its proper headphone. In the "down" position the audio selected is muted.

Emergency operation - In the "up" position the audio selected is muted. In the "down" position the audio selected is summed with any other audios selected and then sent to the headphone.

### **3 - VOLUME CONTROLS**

These concentric knobs adjust headphone volume. The larger one adjusts the radio volume while the smaller one adjusts the intercom volume. Clockwise rotation increases the volume - counter clockwise rotation decreases the volume. In the event of excessive or inadequate receiver volume the pots located on the rear of the unit may be adjusted for the proper level. (see FIGURE 2)

### **4 - LIGHTING**

The audio panel is lit by two 28V lamps which provide night time visibility for all panel legends.

## **ACS 775A-SL Installation and Operations Manual Front Panel Controls (cont'd)**

*(See Figure 1 - Page 8 for pictorial)*

### **5 - MIC SELECTOR**

This rotary switch performs three functions simultaneously. It (a) connects the mic to the selected transmitter (b) selects the associated keyline, and (c) selects the associated audio (if not already selected using the audio select-mute switch).

### **6 - TRANSMIT INDICATOR**

When the transmit key is activated this indicator lights up show that the audio panel is in the transmit mode.

### **7 - ICS SWITCH**

This switch selects the ICS mode. In the " up " position the audio panel is connected to the common ICS buss. This enables the audio panel to communicate with any other audio panels also connected to the common ICS buss. In the "center" position ( OFF ) the audio panel is disconnected from all other panels.

In the "down" position ( HOT ICS ) the headphone mic becomes active and its signal is fed into the ICS buss without having to depress the ICS key switch. This provides for " hands-off " ICS operation.

- ACS 775A-SL Installation and Operations Manual
- Front Panel Controls

■ Figure 1 - Front Panel Controls

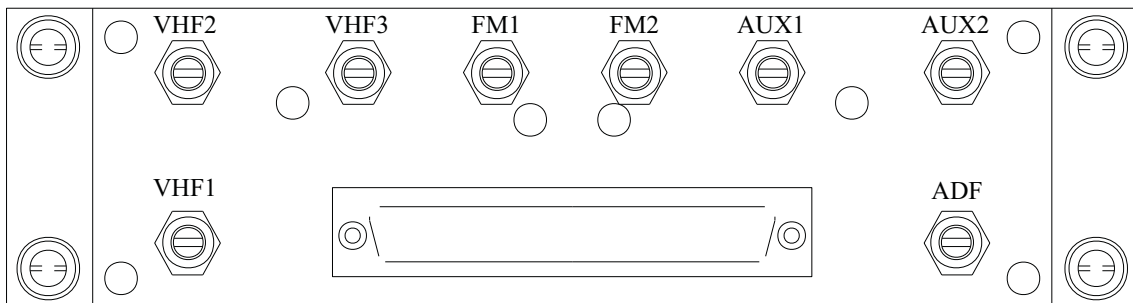
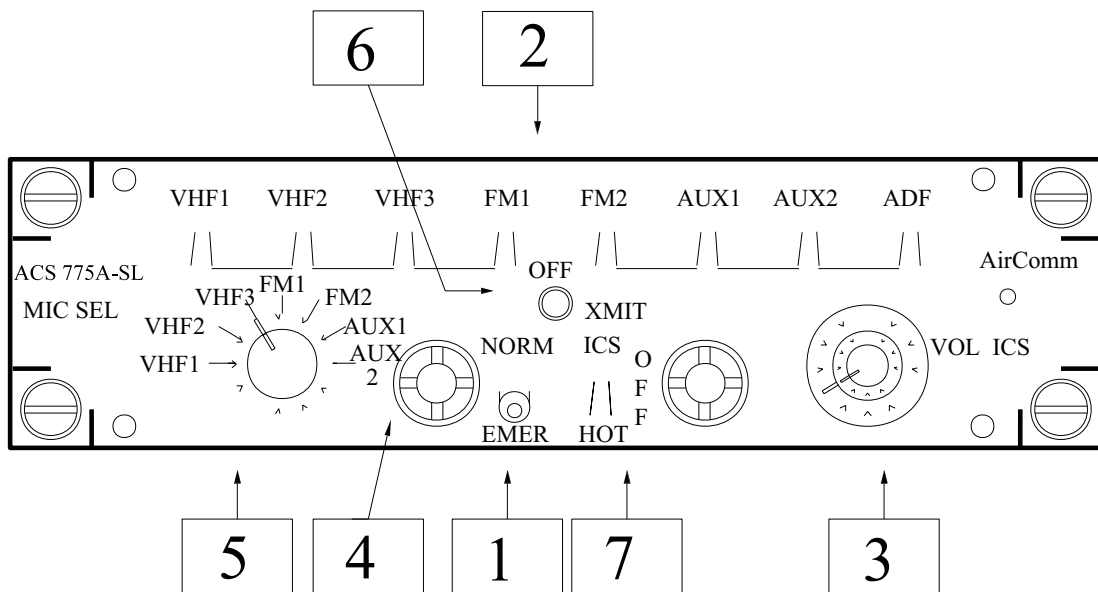

■ FIGURE 2 - REAR PANEL ADJUSTMENT

- **ACS 775A-SL Installation and Operations Manual**
- **Instructions for Continued Airworthiness**

Instruction for continued airworthiness for Audio Mixer Panel Model ACS-775ASL Series, Part Number 1002-400.

- **GENERAL DESCRIPTION:**

- **PURPOSE:**

- To provide instructions for the maintenance and inspection of the Air Comm Systems, Inc. Model ACS-775ASL Series Audio Mixer Panels.

- This Manual provides instructions supplementing the aircraft maintenance manual. These instructions only supersede the aircraft manual in the indicated areas.

- **OPERATIONAL CHECK:**

- The Audio Mixer Panel should be checked prior to first flight each day per current operations manual.

- **MAINTENANCE:**

- Check security and condition of Dzus mounted panel(s), check associated wiring harness at periodic inspections such as annual/100 hour IAW FAR43 Appendix D(i).